

Fusing Equipment

Electrical Apparatus

240-70

EL Bay-O-Net Current-Limiting Fuse Assembly

GENERAL

EL Bay-O-Net fuse assembly from Cooper Power Systems is used to mount the ELS current-limiting fuse in fluid-filled distribution apparatus. The fuse assembly provides the operating convenience of Cooper Power Systems versatile Bay-O-Net expulsion fuse with the energy-limiting capabilities of the current-limiting fuses.

The outer housing, inner holder and handle are made of high strength thermoplastic for application on high-voltage systems at elevated temperatures. An arc follower attached to the lower end of the fuse aids loadbreak switching.

INSTALLATION

No special tools are required. The outer tube is installed into the apparatus side wall and gasket sealed. Refer to Installation and Operating Instruction Sheet, S240-70-1.



Figure 1.
Bay-O-Net Fuse Assembly with hotstick operable hook eye handle.

TABLE 1
Electrical Ratings and Characteristics

Description	kV
Voltage Rating	8.3, 15.5, 23.0
ac 60 Hz 1 Minute Withstand	
8.3 kV	50
15.5 kV	50
23.0 kV	50
BIL and Full Wave Crest	
8.3 kV	150
15.5 kV	150
23.0 kV	150
Minimum Distance from System Ground	
8.3 kV	1.1 in. (28 mm)
15.5 kV	1.5 in. (39 mm)
23.0 kV	2.5 in. (64)
Loadbreak Rating	100 A at 80% pf

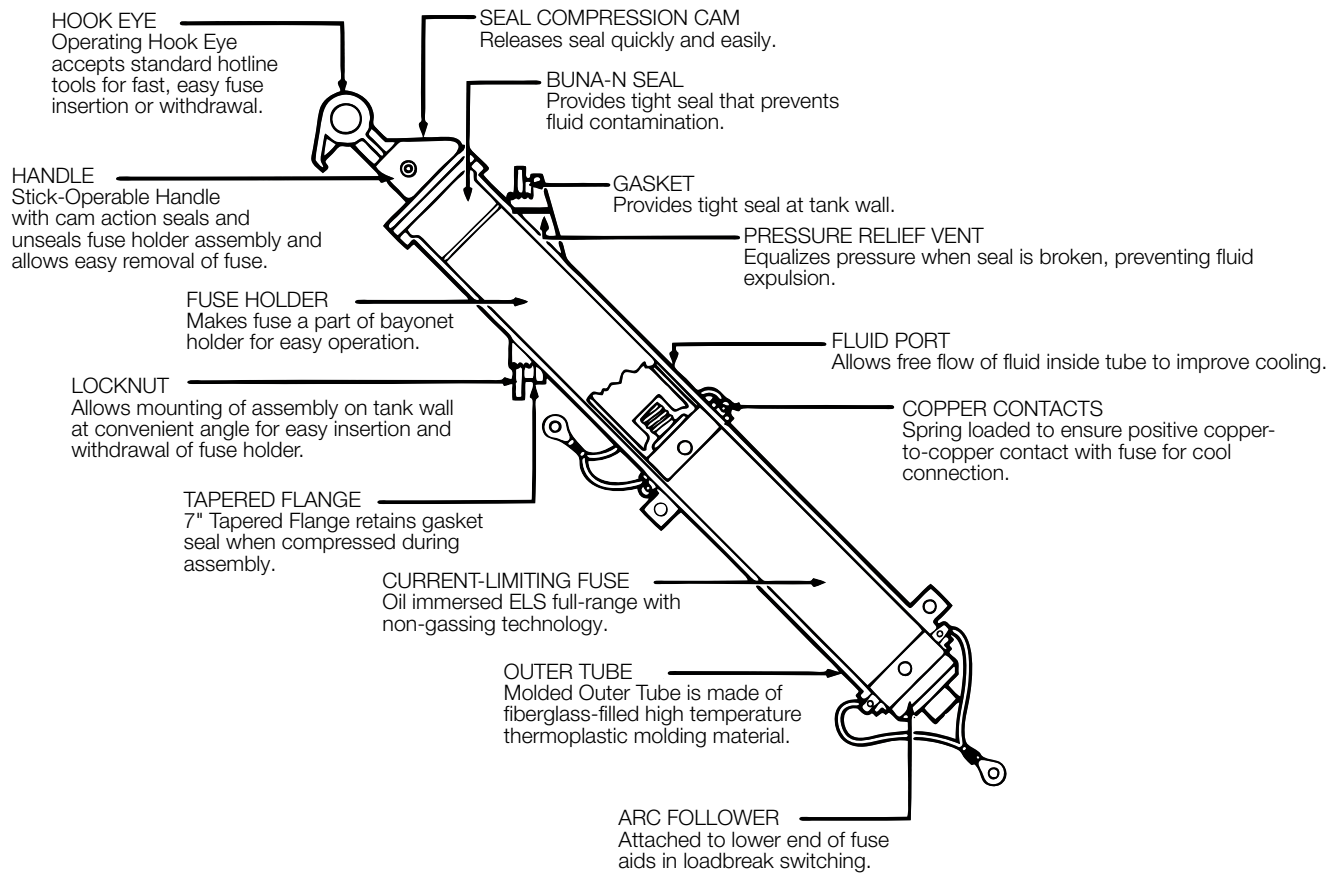

Figure 2.
Cutaway shows feature detail with current-limiting fuse mounted.

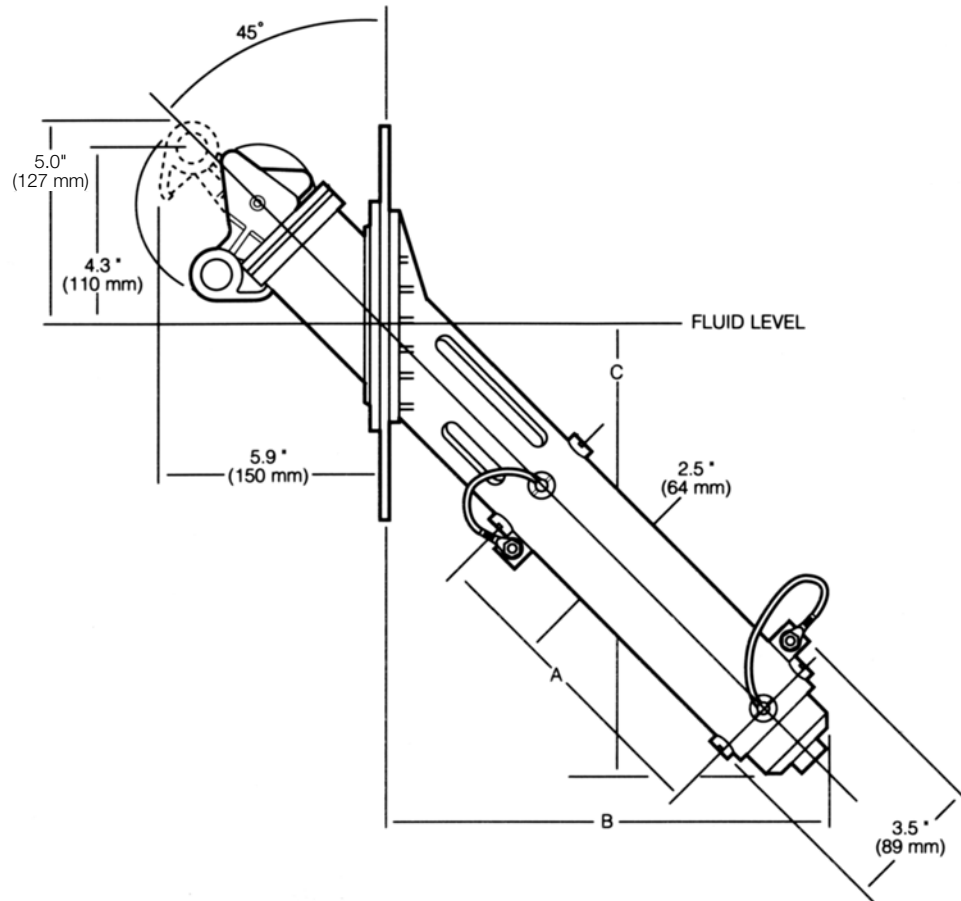

FIGURE 3
Line drawing shows application fluid level and dimensional information.

NOTE: Dimensions given are for reference only.

TABLE 2
Dimensional Information in./.(mm)

Length	8.3 kV	15.5 and 23.0 kV
A	8.22 (209)	16.29 (414)
B	11.31 (287)	17.0 (432)
C	11.65 (296)	17.25 (438)

ORDERING INFORMATION

To order a Cooper Power Systems' EL Bay-O-Net fuse assembly, refer to Tables 3 and 4.

TABLE 3
EL Bay-O-Net Fuse Assemblies

Description	Catalog Number
8.3 kV	
Assembly with 1/4 inch gasket	4004697B01M
Assembly with 3/16 inch gasket	4004697B02M
Solid Link Disconnect	4025117B51
15.5 and 23.0 kV	
Assembly with 1/4 inch gasket	4004697B03M
Assembly with 3/16 inch gasket	4004697B04M
Solid Link Disconnect	4025117B52

TABLE 4
Replacement Parts

Description	Catalog Number
EL Bay-O-Net Stabber (Fuse Holder)	4004693B01
Arc Follower	4025637A01
1/4 inch Gasket	0537980C10
3/16 inch Gasket	0537980C11
Locknut	4009925A01

